

AEROPRAKT
INFORMATION BULLETIN
REPLACEMENT OF THE NOSE LANDING GEAR LEG SPRING OF
A-22 AIRCRAFT
IB A-22-06

MANDATORY

Repeating symbols:

Please, pay attention to the following symbols throughout this document marking important information.

- ▲ **WARNING:** Identifies an instruction, which if not followed may cause serious injury or even death.
- **CAUTION:** Denotes an instruction, which if not followed, may cause severe damage.
- ◆ **NOTE:** Information useful for better handling.

1) Planning information

1.1) Aircraft affected

All versions of Aeroprakt-22 aircraft with metal spring

1.2) Reason

The cracks appear in the nose landing gear spring due to fatigue damage.

1.3) Subject

The nose landing gear leg spring

1.4) Compliance

Replacement of the nose landing gear leg spring is to be carried out on the aircraft after 500 flight hours or 5000 landings

1.5) Approval

The technical content of this Information Bulletin has been approved by Aeroprakt

1.6) Manpower

Estimated man-hours:

Replacement of the nose landing gear leg spring can be performed within an hour

1.7) Mass data

None

1.8) Spare parts

Spare parts are supplied upon request of aircraft owner

2) Special tooling / materials

Clamp, castrol LM

3) Accomplishment / Instructions

3.1) Instructions

(see fig. 1)

3.1.1) spring replacement

- 1) remove the wheel (item 1);
- 2) remove the fairing (item 2);
- 3) compress the spring (item 3) in area of brackets (4) using clamps.
- 4) take out the upper (item 5) and lower (item 6) bolts, remove the spring;
- 5) take the new spring, compress it and install in place of the old one;
- 6) put back the upper and lower bolts and cotter it;
- 7) put the fairing and wheel.

◆ **NOTE:** if the fairing is not installed, it is not necessarily to remove the wheel.

◆ **NOTE:** Lubricate the contacting surface of the brackets (item 4), lower cuff (item 7) and bracket (item 8) before re-installing it.

▲ **WARNING:** if the spring is not replaced in time (1.4), the nose landing gear leg may fail, this will cause the airplane nose-over.

4) Appendix

The following drawing contain additional information

- 1 - Wheel Matko 6.00-6
- 2 - Nose wheel fairing
- 3 - Spring A22.3.4330.00CB
- 4 - Bracket A22.3.4331.00
- 5 - Bolt 6-66-KØ OCT1 31132-80
- 6 - Bolt 6-75-KØ OCT1 31132-80
- 7 - Lower cuff A22.1.4306.00
- 8 - Bracket A22.3.4353.00

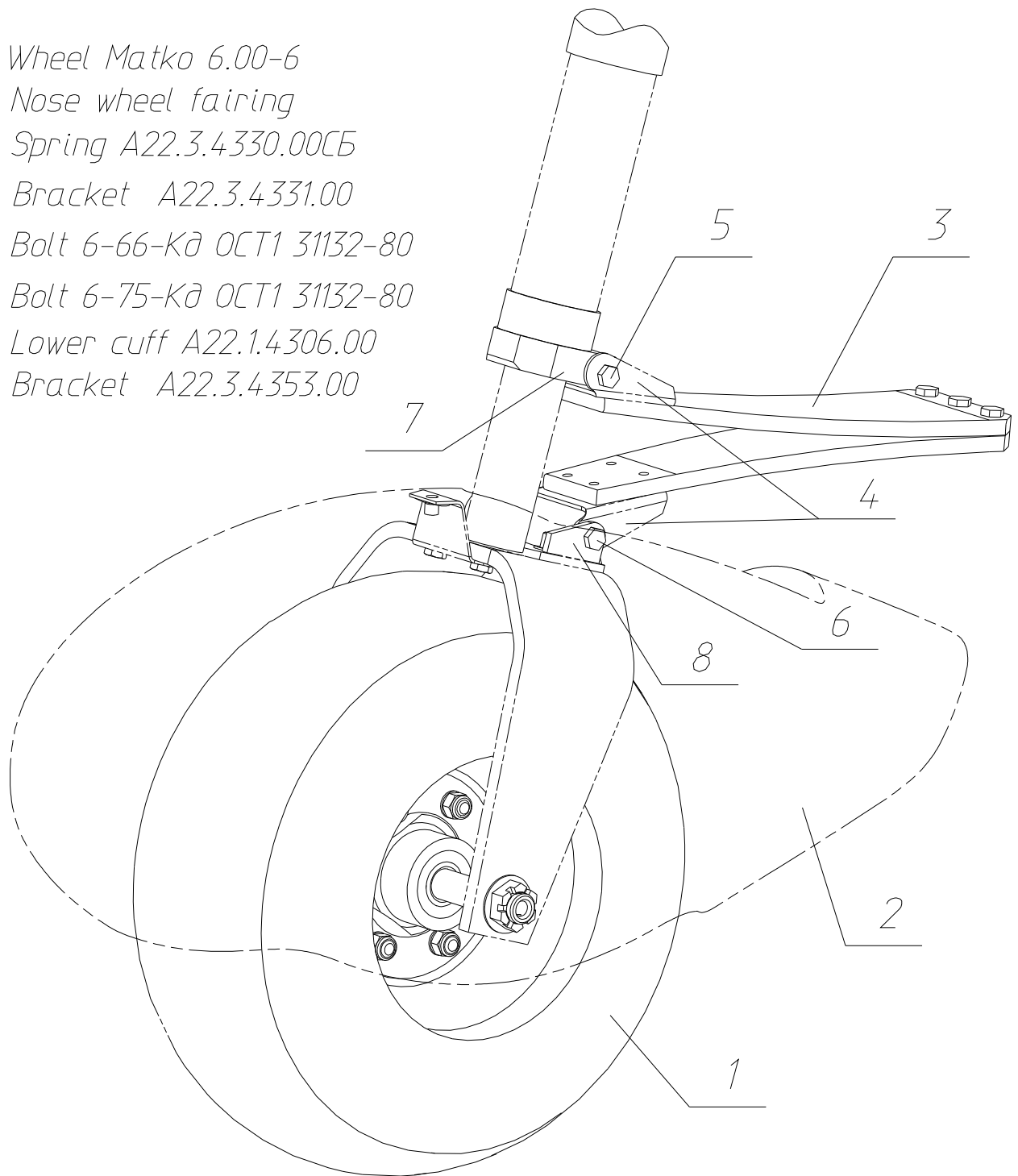

Fig. 1